

# HC-B-AF-SET - Panel-mount flange



1604638

<https://www.phoenixcontact.com/in/products/1604638>

Please be informed that the data shown in this PDF document is generated from our Online Catalog. Please find the complete data in the user documentation. Our General Terms of Use for Downloads are valid.

Panel-mount flange for HEAVYCON ADVANCE housing, set consisting of: 2 panel-mount flanges with 4 self-tapping screws (M4, Torx<sup>®</sup>) and 4 fan-type washers

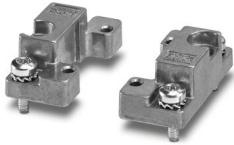

## Commercial Data

Item number	1604638
Packing unit	1 pc
Minimum order quantity	1 pc
Sales Key	BF7
Product Key	BF7APZ
Catalog Page	Page 596 (C-2-2019)
GTIN	4017918893262
Weight per Piece (including packing)	31.1 g
Weight per Piece (excluding packing)	28.7 g
Customs tariff number	85389099
Country of origin	CN

# HC-B-AF-SET - Panel-mount flange

1604638

<https://www.phoenixcontact.com/in/products/1604638>

## Technical Data

### Notes

General	1 for every connector
---------	-----------------------

### Product properties

Type	B6 - B24
Product type	Panel-mount flange
Type	Set of 2 with screws
Housing type	Panel-mount flange
Protective cover	no
Locking type	For screw locking
Pg screw connection	none

### Dimensions

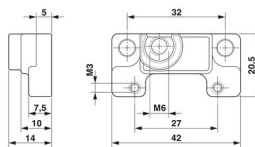
Dimensional drawing	
Width	42 mm
Height	20.5 mm
Depth	14 mm
Hole diameter	4.5 mm

### Material specifications

Material	die-cast aluminum
----------	-------------------

### Mechanical properties

#### Mechanical data

Locking type	Nut
--------------	-----

### Environmental and real-life conditions

#### Ambient conditions

Ambient temperature (operation)	-40 °C ... 125 °C
---------------------------------	-------------------

### Mounting

Assembly instructions	<p>In order to guarantee that the ground conductor contact functions even when plugged in at an angle, the two panel mounting flanges must have sufficient electrical contact with the metal mounting panel.</p> <p>Minimum panel thickness of a steel sheet: 2.0 mm. For mounting with self-tapping M4 screws: 3.6 mm drill-hole diameter</p>
-----------------------	--

# HC-B-AF-SET - Panel-mount flange

1604638

<https://www.phoenixcontact.com/in/products/1604638>



Phoenix Contact 2023 © - all rights reserved

<https://www.phoenixcontact.com>

PHOENIX CONTACT (I) Pvt. Ltd.

A-58/2, Okhla Industrial Area, Phase - II, New Delhi-110 020

+91.1275.71420

[info@phoenixcontact.co.in](mailto:info@phoenixcontact.co.in)