

# HC-STA-B24-SLWD-2SSP21-ELC-AL - Housing



1412875

<https://www.phoenixcontact.com/in/products/1412875>

Please be informed that the data shown in this PDF document is generated from our Online Catalog. Please find the complete data in the user documentation. Our General Terms of Use for Downloads are valid.



Box mounting bases B24, with double locking latch, material: Die-cast aluminum, salt water resistant, cable outlets: 2, lateral, 2x Pg21, height: 68 mm, cable gland: none, Standard

## Your advantages

- Good shielding in the event of electromagnetic interference

## Commercial Data

Item number	1412875
Packing unit	1 pc
Minimum order quantity	1 pc
Sales Key	BF7
Product Key	BF7APB
Catalog Page	Page 637 (C-2-2019)
GTIN	4055626061245
Weight per Piece (including packing)	340.9 g
Weight per Piece (excluding packing)	340 g
Customs tariff number	85389099
Country of origin	PL

# HC-STA-B24-SLWD-2SSP21-ELC-AL - Housing



1412875

<https://www.phoenixcontact.com/in/products/1412875>

## Technical Data

### Notes

General	for contact inserts HC-B24, BB46, D64, DD108, HV10/16, M
---------	--

### Product properties

Type	B24
Product type	Housing with locking latch
Application	Standard
No. of cable outlets	2
Type of the screw connection	2x Pg21
Housing type	Box mounting bases
Locking type	with double locking latch
Cable outlet	lateral
Pg screw connection	none

### Dimensions

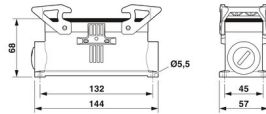
Dimensional drawing	
Width	57 mm
Height	68 mm
Length	144 mm
Hole diameter	5.5 mm

### Material specifications

Color	gray aluminum
Flammability rating according to UL 94	V0 (Interlock)
Seal material	NBR, conductive
Housing surface material	uncoated
Locking latch material	PA
Impact strength	IK09
Housing material	Die-cast aluminum, salt water resistant

### Mechanical properties

#### Mechanical data

Type of the screw connection	2x Pg21
Locking type	Latch

### Mounting

Assembly instructions	One opening is sealed with a plastic filler plug and can be
-----------------------	---

1412875

<https://www.phoenixcontact.com/in/products/1412875>

opened using a screwdriver.

## Environmental and real-life conditions

### Ambient conditions

Degree of protection	IP66
	IP67
	4 (UL 50e)
	4X (UL 50e)
	12 (UL 50e)
Impact strength	IK09
Ambient temperature (operation)	-40 °C ... 125 °C

Phoenix Contact 2023 © - all rights reserved

<https://www.phoenixcontact.com>

PHOENIX CONTACT (I) Pvt. Ltd.

A-58/2, Okhla Industrial Area, Phase - II, New Delhi-110 020

+91.1275.71420

[info@phoenixcontact.co.in](mailto:info@phoenixcontact.co.in)